

# FRANKLIN SENSORS

## ProSensor™ 710+ PROFESSIONAL STUD FINDER

**IMPORTANT: READ BEFORE USING.  
SAVE THESE INSTRUCTIONS.**

### Operating/Safety Instructions

#### FRANKLIN SENSORS PROSENSOR 710+

Congratulations on selecting the most advanced wall sensor on the market. Your ProSensor 710+ incorporates advanced technology that precisely senses the surface in thirteen locations simultaneously, then instantly identifies the location(s) of hidden object(s). It is the easiest-to-use, fastest, and most accurate stud finder on the market.

#### SAFETY RULES FOR THE PROSENSOR 710+

**WARNING: Read all instructions before use. Failure to follow safety instructions may result in electric shock, fire, and/or serious injury and death.**

#### SAVE THESE INSTRUCTIONS

**WARNING:** It is possible that there may be wood, metal, wiring, or other objects behind the surface that are not detected. It is also possible that the stud finder may detect pipes, wires, or other objects that the user may not want it to detect. The stud finder is designed to detect any inconsistency without identifying the nature of the inconsistency. The stud finder does not identify what type of object it detects. The illuminated LEDs may indicate the location of many different features including, but not limited to, studs, beams, water pipes, gas pipes, wires, an inconsistency in the surface material or paint, etc.

**WARNING: TURN OFF** all gas, water, and electric power before using any drilling or penetrating devices or equipment including drills, saws, routers, hammers, nails, screws, etc.

**WARNING:** The stud finder alone should not be relied upon exclusively to locate objects behind a scanned surface. Use other sources of information to help locate objects. Other sources of information may include, but is not limited to, construction plans, visible points of entry of pipes, location of switches and outlets, and standard 16" and 24" stud spacing practices.

**FAILURE TO TAKE THESE AND OTHER NECESSARY PRECAUTIONS COULD RESULT IN ELECTRIC SHOCK, FIRE, AND/OR SERIOUS INJURY AND DEATH.**

**Clean**  
Before turning on, ensure that the stud finder is clean and dry. If necessary, wipe the stud finder dry using a clean cloth. If the detector is wet or dirty it may not operate properly.

**Temperature**  
If the stud finder is subject to a significant temperature change, allow it adjust to the ambient temperature before using. The entire area of the sensor board should be at a similar temperature for best operation.

### OPERATING INSTRUCTIONS

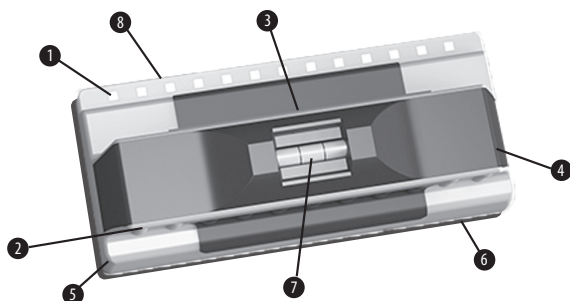

1. LED Lights
2. Ergonomic Handle
3. "On" Button
4. Battery Cover
5. Detector Housing
6. Sensor Board
7. Bubble Level
8. Ruler

#### TO OPERATE:

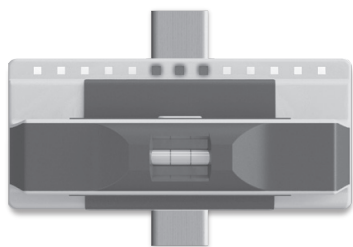

- Hold the stud finder by the handle. Do not touch the detector outside of the handle area while scanning.
- Place the ProSensor 710+ firmly against the surface and press the "on" button. Continue to hold the "on" button down.
- LED lights will immediately display the location of any hidden objects.
- The "on" button may be pressed before or after placing the stud finder on the surface to be scanned. The stud finder will detect studs without sliding the stud finder across the wall, but will also operate correctly if it is slid across the wall.

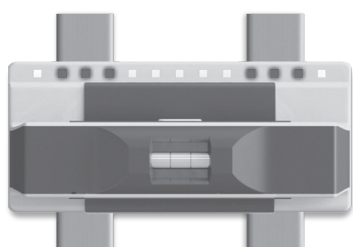

- If more than one hidden object is present, the stud finder will show the location of more than one hidden object.

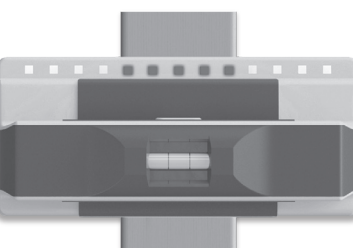

- LED lights indicate the width of hidden object(s).

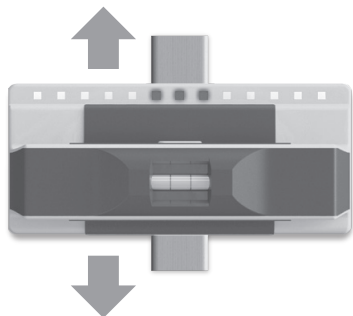

- On some surfaces it may be helpful to slide the stud finder up and down to confirm the location of a stud.

#### SENSING THROUGH DIFFERENT MATERIALS:

##### Moisture

The scanned surface should be clean and dry. Paint and wallpaper need to be completely dry before scanning for studs. It may take up to 2 weeks for wallpaper to dry enough to detect studs.

##### Curved Surfaces

There is a minor degree of curvature in the walls of most homes and buildings. The curvature is small enough that it may not be noticed. The ProSensor 710+ can detect objects through curved surfaces because the ProSensor 710+ has a sensor board that bends slightly to match the contour of most walls. Press the stud finder firmly against the surface and the sensor board will match the contour of the surface, and provide the best reading.

##### Foil-Backed Insulation

Although foil covered insulation is not very common, metal foil can cause inconsistent readings with all electronic stud finders, including the ProSensor 710+.

##### Metallic Content in Wallpaper

Wallpaper with metallic content can block the detector's signals.

##### Textured Walls and Acoustic Ceilings

The ProSensor 710+ is capable of detecting studs through many textured surfaces. The stud finder should be placed firmly against the surface for best results.

##### Lath and Plaster

Irregularities in plaster thickness and variations in construction materials can make it difficult to locate studs behind lath and plaster walls. Also, if the plaster has a mesh reinforcement, the stud finder may not be able to detect through the metal mesh. Although many users have success with the ProSensor 710+ on lath and plaster walls, there is no guarantee the ProSensor 710+ will work on all lath and plaster walls.

##### Tile, Flooring, Roofing, and Outside of House

The ProSensor 710+ works by measuring the density of material behind the sensors to determine the location of studs. Due to the variability in the density of materials in tile, flooring, roofing, and on the outside of the house, we do not recommend the ProSensor 710+ for use in these applications.

#### STICKERS / DECALS

Do not place decals or stickers, especially metal decals or stickers on the sensor board, or on the stud finder in any place.

#### DISASSEMBLY / TEFLON PADS

Do not disassemble the stud finder or remove the teflon pads that are on the bottom. The stud finder will not operate correctly without the teflon pads properly in place.

#### BATTERIES

The ProSensor 710+ uses 2 AA batteries. Use alkaline batteries only; do not use rechargeable batteries. Replace both batteries at the same time.

#### REPLACING THE BATTERIES

- Remove battery cover, by sliding the cover to the left and lifting. Remove batteries and dispose of the batteries properly. Please recycle.

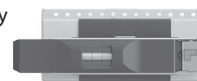

- Replace with 2 new AA alkaline batteries.

- Replace battery cover. Close battery cover by sliding the cover to the right until it snaps into place.

#### STORAGE

Store the stud finder in a clean, dry place at room temperature. Protect against direct sunlight and moisture.

#### ENVIRONMENTAL CONDITIONS

Storage Temperature	0°F to 120°F (-18°C to 50°C)
Operating Temperature	32°F to 110°F (0°C to 43°C)
Storage Humidity	0% to 90% relative humidity (non-condensing)
Operating Humidity	0% to 90% relative humidity (non-condensing)

#### DISPOSAL

Stud finders and packaging should be sorted for recycling.

#### FCC PART 15 CLASS B REGISTRATION WARNING

This device complies with Part 15 of FCC rules. Operation is subject to the following two conditions:

1. This device may not cause harmful interference, and
2. This device must accept any interference received, including interference that may cause undesired operation.

### TROUBLESHOOTING

CONDITION	PROBABLE CAUSE	SOLUTION
No LED lights come on.	Weak battery.	Replace with 2 new AA alkaline batteries.
Stud finder only works momentarily.	The "on" button isn't being held down.	Hold the "on" button down until you have completed your scan.
The LED lights are indicating the location of pipes and wires, not just studs.	The ProSensor 710+ indicates the location of inconsistencies. The LED lights may indicate the location of a pipe, electrical wiring, other objects near the surface being scanned, or an inconsistency in the surface material or paint, etc.	Look for evenly placed studs on either side (16", 24", on center, etc.) Scan above the location and below the location to confirm results. Use caution before penetrating wall. See the SAFETY RULES FOR THE PROSENSOR 710+.
Difficulty starting a scan near doors and windows.	Double studs, triple studs and solid headers are often present around doors and windows. The stud finder requires the presence of a region without studs to correctly identify studs.	Begin the scan away from the window or door, then move the stud finder to the area around the window or door. For best results, keep stud finder 3" away from wood trim, outlets, switches, etc.
Stud finder doesn't work through new wall paper.	The moisture in the wall after wall papering can block the stud finder's signal.	Wait until the wallpaper is dry. It may take up to 2 weeks for the paper to dry sufficiently.
My house was built prior to about 1960. The walls are lath and plaster. The stud finder doesn't work very well anywhere in my house.	Older houses that were built with lath and plaster, instead of sheet rock, often have too much inconsistency in the walls for the detector to work reliably.	Try using the stud finder at a higher point on the wall, or a lower point on the wall.
Inconsistent readings.	Curved surface.	Press the stud finder firmly against the wall so that the contour of the sensor board matches the slight contour of the wall.
	Anomaly in the surface material.	Test at a higher location, or lower location on the wall.
	Sometimes after scanning the wall for a period of time the readings seem to be less consistent.	Release the button and press the button again.
When I put my hand in front of the sensor board, the readings are not what I would expect.	The stud finder is designed for detecting features in walls, not hands.	Place the stud finder on the wall to detect hidden features.
The LED lights sometimes seem to light up sporadically or inconsistently.	Wires, pipes, or other construction inconsistencies can cause erratic or erroneous readings. Features on the opposite side of a wall may also be a source of inconsistent readings.	Test at points on the wall that are higher, or lower. The stud finder may also work best if it is used more than 3 inches away from metal objects such as outlets, light switches, etc.

### WARRANTY

Franklin Sensors warrants this product to be free from defects in material and workmanship for one year. This LIMITED WARRANTY does not cover products that are improperly used, abused, or altered. Defective products will be replaced or repaired. If a product is found to be defective within the warranty period, Franklin Sensors will, at its sole discretion, either repair or replace the defective product. This limited warranty does not apply to products that are subjected to freight damage, accident, abuse, alteration, misuse, improper repair, etc. Franklin Sensors and Franklin Sensors' authorized distributors shall bear no other liability or obligation under this warranty.

Franklin Sensors does not authorize any person or representative to assume or grant any other warranty or obligation with the sale of this product. Franklin Sensors' limited warranty is valid only if you retain proof of purchase from Franklin Sensors or a Franklin Sensors authorized dealer for this product. If you purchase this product from any other source, your purchase is "AS IS," which means Franklin Sensors grants you no warranty, and that you, not Franklin Sensors, assume the entire risk of the quality and performance of this product. The warranty period for any replaced and/or repaired part under this warranty shall expire at the end of the original warranty period.

ALL EXPRESS AND IMPLIED WARRANTIES FOR THIS PRODUCT, ARE LIMITED IN DURATION TO THE WARRANTY PERIOD, AND NO WARRANTIES, WHETHER EXPRESS OR IMPLIED, WILL APPLY AFTER THIS PERIOD. THIS WARRANTY IS EXCLUSIVE AND IN LIEU OF ALL OTHER OBLIGATIONS, LIABILITIES OR WARRANTIES. In no event shall Franklin Sensors or its licensed distributors be liable or responsible for INCIDENTAL OR CONSEQUENTIAL DAMAGES or for any other direct or indirect damage, loss, cost, expense or fee. Some states do not allow the exclusion or limitation of incidental or consequential damages, so this exclusion or limitation may not apply to you. This warranty gives you specific legal rights and you may also have other rights that vary from state to state.

US Patents 8,476,912 8,593,163 8,669,772  
8,736,283 8,791,708 8,836,347 8,884,633  
US and Foreign Patents Pending.

In the event of a product defect, please return the product postage paid with proof of purchase to:

Franklin Sensors Inc.  
Attn: Returns Department  
13601 W. McMillan Road Suite 102 - 170  
Boise, ID 83713  
(208) 918-2403  
returns@franklinsensors.com  
Hours of Operation: Monday-Friday,  
8 AM to 5 PM,  
Mountain Time Zone